

IN SINK ERATOR®

Model 55 0.55 Horsepower

Food Waste Disposer

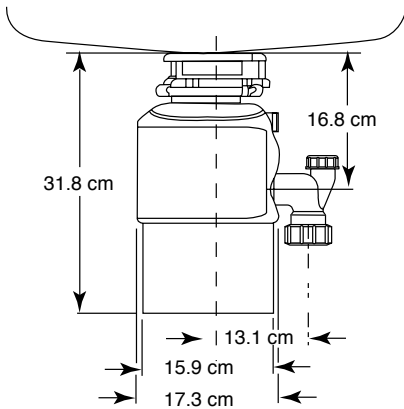

NOTE: Plumb waste line to prevent standing water in disposer motor housing.

Submittal Sheet

- .55 HP Dura-Drive™ heavy-duty induction motor
- Continuous-feed operation
- 3 year full warranty*
- Standard Quiet System: single sound baffle, shell protection, standard EPS insulation
- Engineered resin grind chamber won't corrode
- Cast stainless steel 360° swivel lugs
- Permanently lubricated upper and lower bearings
- Quick-Lock™ mounting assembly for faster, easier installation
- Standard stainless steel sink flange
- Plastic sink stopper
- Overload protection - manual reset switch
- Single sound baffle
- Stainless steel shredder ring for the toughest grinding performance
- Stainless steel rotating shredder
- Jam-buster wrenchette included to free any jams

Specifications

Type of Feed	Continuous		
On/Off	Wall Switch or Air Switch (optional accessory)		
Motor	Induction, Split Phase		
Horsepower	0.55		
Volts (V)	220-240	220-240	120
Hertz (Hz)	50	50	60
RPM	1425	1425	1725
Average Load	370 W	370 W	7.1 A
Lubrication	Permanently lubricated upper & lower bearings		
Shipping Weight	7.160 kg		
Unit Finish	Gray Enamel		
Overall Height	31.8 cm		
Grind Chamber Capacity	980 mL		
Motor Protection	Manual reset overload		
Average Water Usage	1 L per person per day		
Average Electrical Usage	0.5 Kilowatt-Hour per month		
Dishwasher Drain Connection	Yes		

Sample Specification

Food Waste Disposer(s) shall be: In-Sink-Erator Model 55, continuous feed, with .55 H.P. motor, stainless steel grinding elements with two cast stainless steel 360° swivel lugs. Self-service wrenchette. 3 year full warranty.

* The complete In-Sink-Erator warranty is included in the Care & Use Booklet, packed with each unit.

Separate user manual also included.

Job Specifications

